

EE 435

Lecture 10

Laboratory Support

Positive Feedback Amplifier

Transconductance vs Voltage Gain

OTA circuits

Current Mirror Op Amps

- Alternative perspective
- Loop phase-shift concerns

Lab Support:

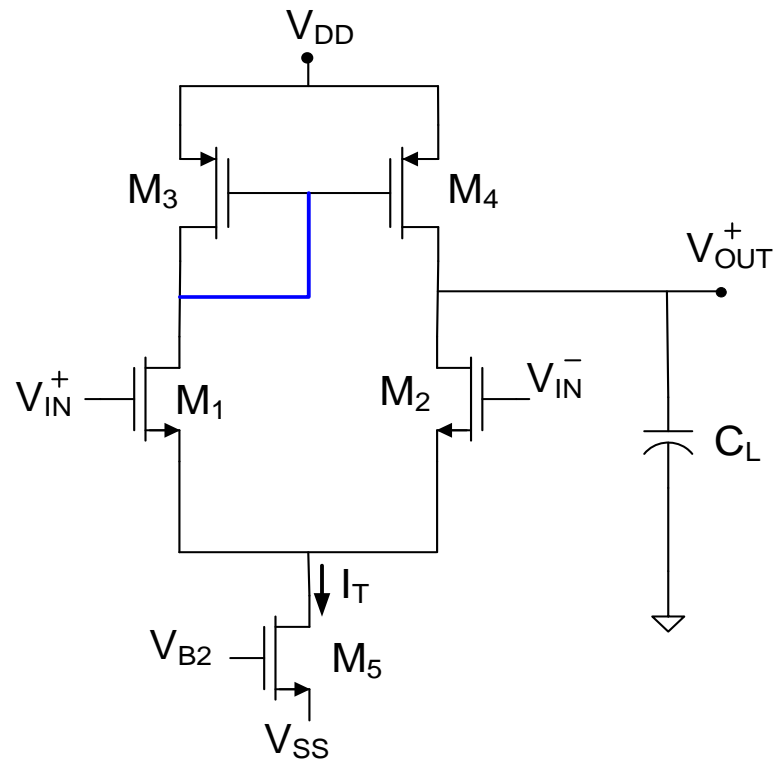

Design space for single-stage op amp

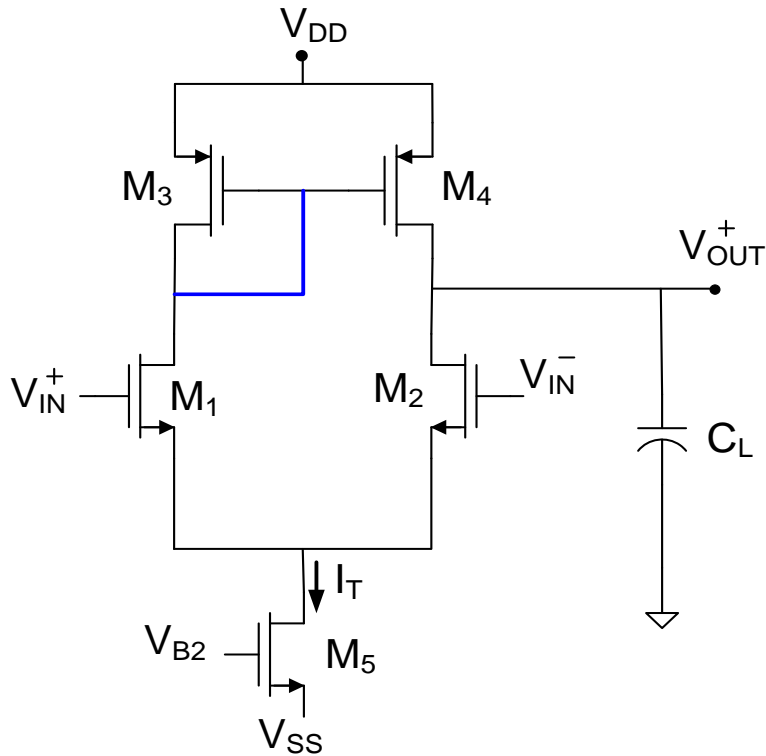

Performance Parameters in Practical Parameter Domain $\{V_{EB1} V_{EB3} V_{EB5} P\}$:

$$A_0 = \left[\frac{1}{\lambda_1 + \lambda_3} \right] \left(\frac{2}{V_{EB1}} \right)$$

$$GB = \left(\frac{P}{V_{DD} C_L} \right) \left[\frac{1}{V_{EB1}} \right]$$

$$SR = \frac{P}{(V_{DD} - V_{SS}) C_L}$$

$$V_{OUT} < V_{DD} - |V_{EB3}|$$

$$V_{OUT} > V_{ic} - V_{T2}$$

$$V_{ic} < V_{DD} + V_{T1} - |V_{T3}| - |V_{EB3}|$$

$$V_{ic} > V_{T1} + V_{EB1} + V_{EB5} + V_{SS}$$

Simple Expressions (7) in Practical Parameter Domain

Design example for single-stage op amp

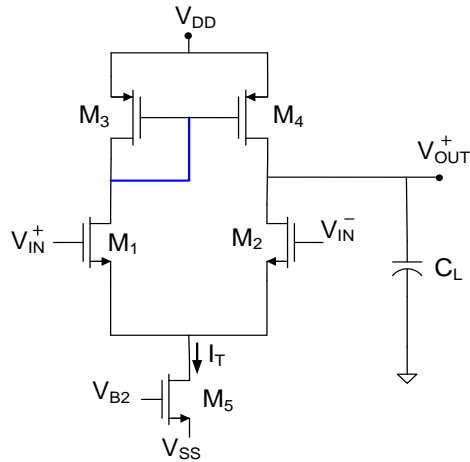

Performance Parameters in Practical Parameter Domain $\{V_{EB1} V_{EB3} V_{EB5} P\}$:

$$A_0 = \left[\frac{1}{\lambda_1 + \lambda_3} \right] \left(\frac{2}{V_{EB1}} \right)$$

$$GB = \left(\frac{P}{V_{DD} C_L} \right) \left[\frac{1}{V_{EB1}} \right]$$

$$SR = \frac{P}{(V_{DD} - V_{SS}) C_L}$$

$$V_{OUT} < V_{DD} - |V_{EB3}|$$

$$V_{OUT} > V_{ic} - V_{T2}$$

$$V_{ic} < V_{DD} + V_{T1} - |V_{T3}| - |V_{EB3}|$$

$$V_{ic} > V_{T1} + V_{EB1} + V_{EB5} + V_{SS}$$

Assume design to meet A_0 , GB and signal swing specs.

1. Select Parameter Domain (will use practical parameter domain)

$$\{V_{EB1} V_{EB3} V_{EB5} P\}$$

2. Pick V_{EB1} to meet gain requirement) $\{ \cancel{V_{EB1}} V_{EB3} V_{EB5} P \}$

$$V_{EB1} = \left[\frac{1}{\lambda_1 + \lambda_3} \right] \left(\frac{2}{A_0} \right)$$

3. Pick P to meet GB requirement $\{ \cancel{V_{EB1}} V_{EB3} V_{EB5} \cancel{P} \}$

4. Pick V_{EB3} and V_{EB5} to meet signal swing requirements

5. Map back from the Practical Parameter Domain to the Natural Parameter domain (next page)

Design example for single-stage op amp

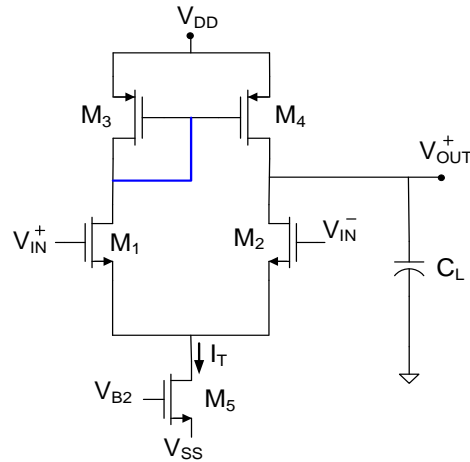

Performance Parameters in Practical Parameter Domain $\{V_{EB1} V_{EB3} V_{EB5} P\}$:

Mapping from Practical Parameter Domain $\{V_{EB1} V_{EB3} V_{EB5} P\}$ to Natural Parameter Domain $\{W_1/L_1 W_3/L_3 W_5/L_5 I_T\}$

From expression $I_{Dk} = \frac{\mu_k C_{ox} W_k}{2L_k} V_{EBk}^2$ it follows that

$$\frac{W_1}{L_1} = \frac{1}{\mu_n C_{OX} V_{EB1}^2} \frac{P}{V_{DD} - V_{SS}}$$

$$\frac{W_3}{L_3} = \frac{1}{\mu_p C_{OX} V_{EB3}^2} \frac{P}{V_{DD} - V_{SS}}$$

$$\frac{W_5}{L_5} = \frac{2}{\mu_n C_{OX} V_{EB5}^2} \frac{P}{V_{DD} - V_{SS}}$$

$$I_T = \frac{P}{V_{DD} - V_{SS}} \quad \text{or} \quad V_{B2} = V_{EB5} + V_{ss} + V_{THn}$$

Design Space Exploration

Consider the 5T Op Amp with CM Biasing

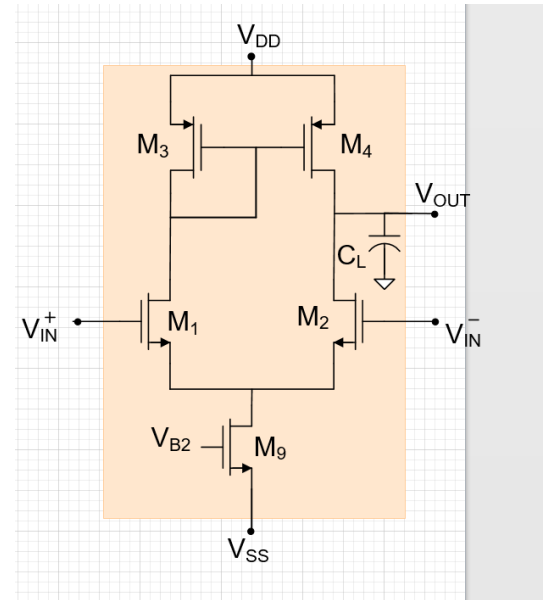

5T Op Amp Design

Process Parameters

μCOX	350	μAV^2
μPCOX	75	μAV^2
$V\text{THn}$	0.4	V
$V\text{THp}$	-0.4	V
λ	0.01	V^{-1}

Fixed Constraints

$V\text{DD}$	2	V
$V\text{SS}$	-2	V
$C\text{L}$	10	pf
$L1=L2=\dots=L$	0.5	μm
k	0.6	V

Input Quantities in

Op Amp

Design Variables

No	$V\text{EB1}$	$V\text{EB3}$	$V\text{EB9}$	P (mw)
1	0.1	-0.1	0.1	5
2	0.2	-0.2	0.1	5
3	0.4	-0.1	0.1	5
4	0.05	-0.1	0.1	5
5	0.1	-0.1	0.1	1
6	0.1	-0.1	0.1	10
7	0.1	-0.1	0.1	0.1
8	0.1	-0.1	0.1	20
9	0.1	-0.1	0.2	1
10	0.1	-0.2	0.1	0.1

Performance Characteristics

A0	BW (MHz)	GB (MHz)	SR (V/ μs)	$V\text{omax}$	$V\text{omin}$	$V\text{CM}$	$I\text{T}$ (mA)
1000	0.20	199.04	0.125	1.9	0	0.1	1.25
500	0.20	99.52	0.125	1.8	-0.1	0.1	1.25
250	0.20	49.76	0.125	1.9	-0.3	0.1	1.25
2000	0.20	398.09	0.125	1.9	0.05	0.1	1.25
1000	0.04	39.81	0.025	1.9	0	0.1	0.25
1000	0.40	398.09	0.25	1.9	0	0.1	2.5
1000	0.00	3.98	0.0025	1.9	0	0.1	0.025
1000	0.80	796.18	0.5	1.9	0	0.1	5
1000	0.04	39.81	0.025	1.9	0	0.1	0.25
1000	0.00	3.98	0.0025	1.8	0	0.1	0.025

Practical Design Values in μm

W1	W2	W3	W4	W9
357.1	357.1	1666.7	1666.7	714.3
89.3	89.3	416.7	416.7	714.3
22.3	22.3	1666.7	1666.7	714.3
1428.6	1428.6	1666.7	1666.7	714.3
71.4	71.4	333.3	333.3	142.9
714.3	714.3	3333.3	3333.3	1428.6
7.1	7.1	33.3	33.3	14.3
1428.6	1428.6	6666.7	6666.7	2857.1
71.4	71.4	333.3	333.3	35.7
7.1	7.1	8.3	8.3	14.3

Small Signal Parameters (if desired)

$g\text{m1}$	$g\text{m3}$	$g\text{m9}$	$g\text{o1}$	$g\text{o3}$	$g\text{o9}$
0.0125	0.0125	0.025	6.25E-06	6.25E-06	1.3E-05
0.00625	0.00625	0.025	6.25E-06	6.25E-06	1.3E-05
0.003125	0.0125	0.025	6.25E-06	6.25E-06	1.3E-05
0.025	0.0125	0.025	6.25E-06	6.25E-06	1.3E-05
0.0025	0.0025	0.005	1.25E-06	1.25E-06	2.5E-06
0.025	0.025	0.05	1.25E-05	1.25E-05	2.5E-05
0.00025	0.00025	0.0005	1.25E-07	1.25E-07	2.5E-07
0.05	0.05	0.1	0.000025	0.000025	0.00005
0.0025	0.0025	0.0025	1.25E-06	1.25E-06	2.5E-06
0.00025	0.000125	0.0005	1.25E-07	1.25E-07	2.5E-07

Design Space Exploration

Embedded Spreadsheet

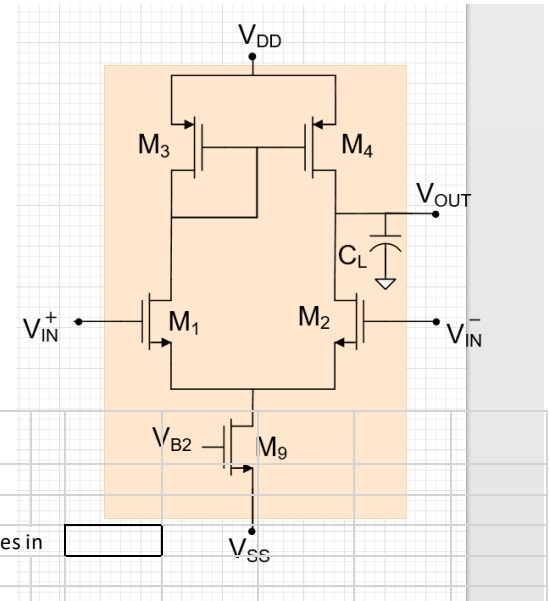

5T Op Amp Design																	
Process Parameters					Fixed Constraints					Input Quantities in <input type="text"/>							
	μCOX	350	μAV^2		V_{DD}	2	V										
	μPCOX	75	μAV^2		V_{SS}	-2	V										
	V_{THn}	0.4	V		C_{L}	10	pf										
	V_{THp}	-0.4	V		$L_1=L_2=\dots=L_N$	0.5	um										
	λ	0.01	V^{-1}		V_{B2}	0.6	V										
Op Amp	Design Variables				Performance Characteristics								Practical Design Values in um				
No	VEB1	VEB3	VEB9	P (mw)	A0	BW (MHz)	GB (MHz)	SR (V/uS)	Vomax	Vomin	VCM	IT (mA)	W1	W2	W3	W4	W9
1	0.1	-0.1	0.1	5	1000	0.20	199.04	0.125	1.9	0	0.1	1.25	357.1	357.1	1666.7	1666.7	714.3
2	0.2	-0.2	0.1	5	500	0.20	99.52	0.125	1.8	-0.1	0.1	1.25	89.3	89.3	416.7	416.7	714.3
3	0.4	-0.1	0.1	5	250	0.20	49.76	0.125	1.9	-0.3	0.1	1.25	22.3	22.3	1666.7	1666.7	714.3
4	0.05	-0.1	0.1	5	2000	0.20	398.09	0.125	1.9	0.05	0.1	1.25	1428.6	1428.6	1666.7	1666.7	714.3
5	0.1	-0.1	0.1	1	1000	0.04	39.81	0.025	1.9	0	0.1	0.25	71.4	71.4	333.3	333.3	142.9
6	0.1	-0.1	0.1	10	1000	0.40	398.09	0.25	1.9	0	0.1	2.5	714.3	714.3	3333.3	3333.3	1428.6
7	0.1	-0.1	0.1	0.1	1000	0.00	3.98	0.0025	1.9	0	0.1	0.025	7.1	7.1	33.3	33.3	14.3
8	0.1	-0.1	0.1	20	1000	0.80	796.18	0.5	1.9	0	0.1	5	1428.6	1428.6	6666.7	6666.7	2857.1
9	0.1	-0.1	0.2	1	1000	0.04	39.81	0.025	1.9	0	0.1	0.25	71.4	71.4	333.3	333.3	35.7
10	0.1	-0.2	0.1	0.1	1000	0.00	3.98	0.0025	1.8	0	0.1	0.025	7.1	7.1	8.3	8.3	14.3

Positive Feedback Amplifier

From homework Problem 6 Assignment 1

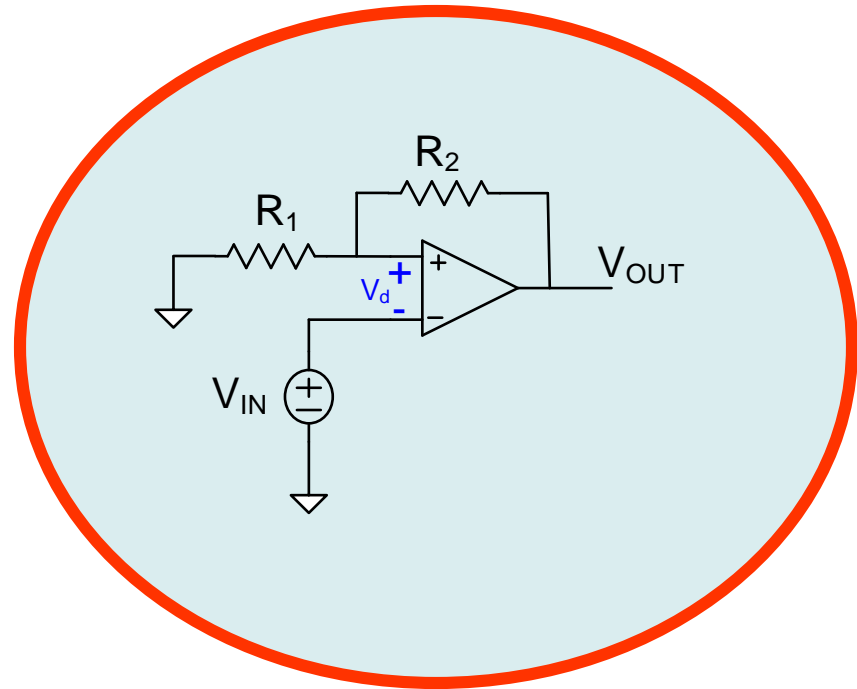
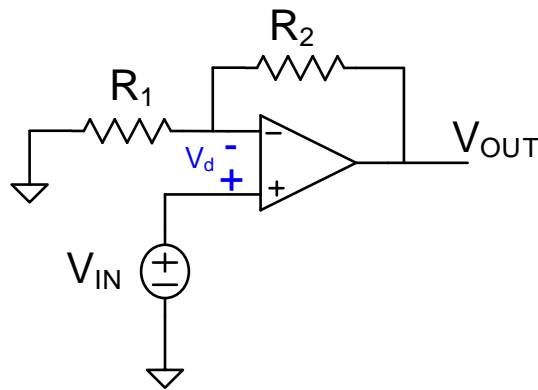

Homework Problem 6 Assignment 1

Problem 6 Two circuits that use a single operational amplifier are shown below.

- Using the model of the standard model of the operational amplifier that appears in the Sedra/Smith book, analyze the two circuits under the assumption that the voltage gain of the op amp, A_V , is finite.
- Compare the voltage gain of the two circuits as the voltage gain A_V goes to ∞
- Although an engineer should be able to analyze any interconnection of basic devices and components, almost all basic electronics textbooks are silent on the existence of the simple circuit on the right. Why is this circuit is seldom discussed? Support your answer with sound analytical principles or concepts.

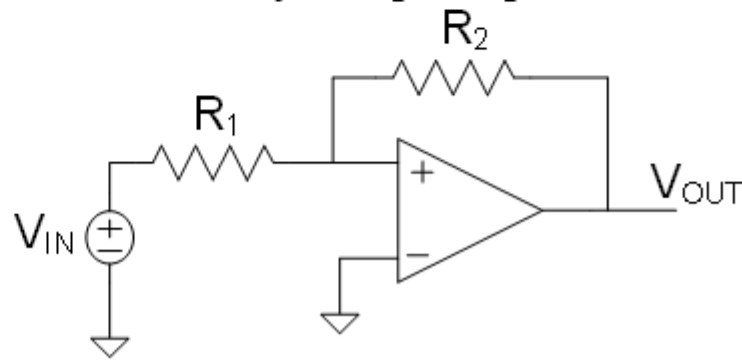
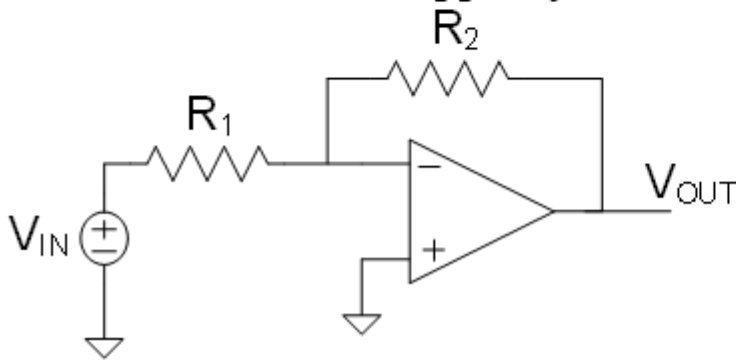

Most got the first parts right but nobody rigorously assessed the performance of the circuit with positive feedback

Are engineers expected to know how interconnections of basic circuit elements perform?

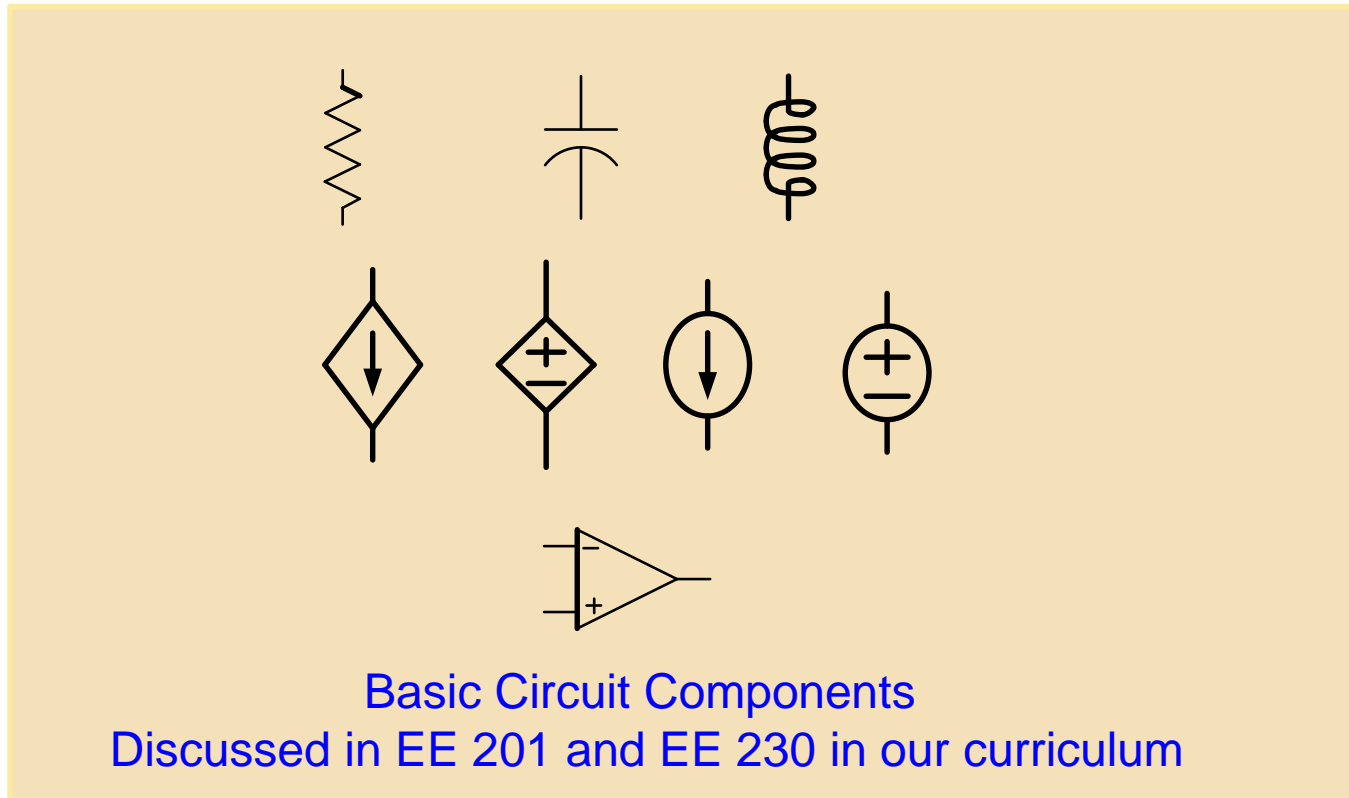

Design engineers are invariably and routinely required to create new interconnections of these basic components to solve existing problems

Designers are often guided by previous design that often appears in text books or other literature

Are engineers expected to know how interconnections of basic circuit elements perform?

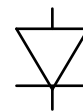
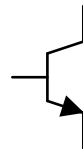
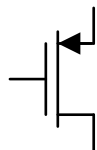
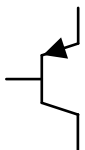
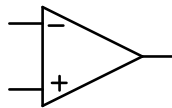
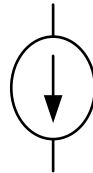
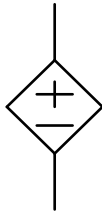
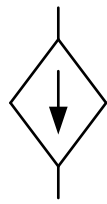
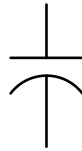

Homework Problem 6 Assignment 1

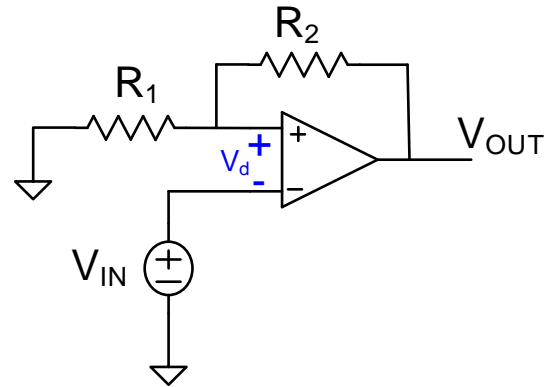
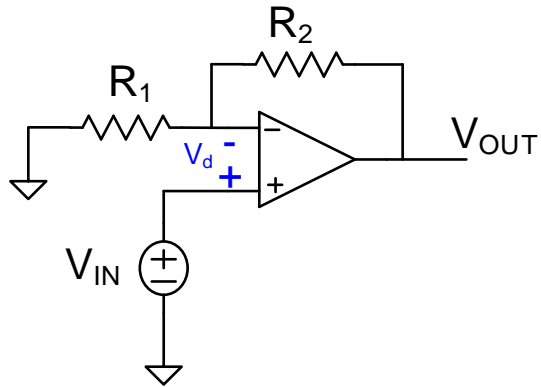

Sedra Smith Analysis
(for circuit on left)

1. Assume Op Amp operating linearly (not stated)
2. Since A_v large, conclude $V_d=0$
3. Apply KCL at node between resistors

$$V_{IN} \frac{1}{R_1} + (V_{IN} - V_{OUT}) \frac{1}{R_2} = 0$$

4. Solve to obtain

$$V_{OUT} = \left(1 + \frac{R_2}{R_1} \right) V_{IN}$$

Identical analysis applies for circuit on right so get identical results

If op amps are ideal based upon the models introduced in most texts, and based upon the analysis presented in the most recent edition of the Sedra Smith text, both circuits have the same input-output relationship

Homework Problem 6 Assignment 1

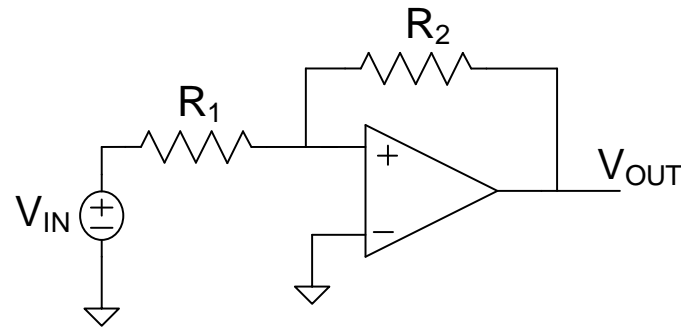

c) Although an engineer should be able to analyze any interconnection of basic devices and components, almost all basic electronics textbooks are silent on the existence of the simple circuit on the right. Why is this circuit seldom discussed? **Support your answer with sound analytical principles or concepts.**

Why is this issue important?

How can you trust or be confident in your analysis and understanding if the principles you use to analyze even some of most basic circuits fail in slightly different circuits?

Why is this circuit is seldom discussed?

Support your answer with sound analytical principles or concepts.

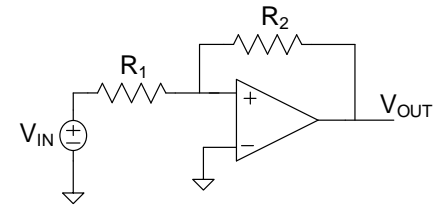

Selected Answers from Students

When the circuit on the right has a finite A_V the gain increases and when the circuit on the left has a finite A_V the gain decreases

The circuit on the right is seldom used because as A_V goes to infinity is unrealistic.

The circuit on the right isn't talked about as much because of the possibility for an undefined gain.

A positive feedback works in a saturation region. ...the output will move to the upper or lower bounds and will stay there until a big change in the input occurs.

Non-inverting op amp provides positive feedback which can cause stability issues in some applications when compared to the certain negative feedback with an inverting op amp

V- is the inverting input and what is displayed is an inverting op amp when the input voltage is applied to V+ it becomes a non-inverting op amp and that is not the circuit that is used as a typical non-inverting op amp

Selected Answers from Students

Since it is positive feedback, the output voltage will saturate at the power supply voltage, the stability is not good as that of negative feedback amplifier.

...consequently this circuit though with applications to oscillatory circuits is seldom discussed for designing amplifiers.

The whole reason the circuit on the left works is because of negative feedback.

The reason why the configuration on the right is seldom used is because it is a positive feedback circuit ...

...the circuit is seldom discussed because it is extremely hard to analyze ...

The second circuit is seldom discussed because it realizes positive feedback which, unless used carefully and purposefully, saturates the op amp's output making the circuit useless. One potentially useful application ... would be a simple comparator ... See Problem 2.29

Selected Answers from Students

2.29 An inverting amplifier is accidentally connected with positive feedback as illustrated in Fig. P2.29. Assuming the op amp has a finite gain A , find an expression for the closed-loop gain, v_O/v_I . Show that if $A = 1 + (R_2/R_1)$, the closed-loop gain becomes infinite, indicating instability. Real op-amp gain varies with input frequency so that instability is practically inevitable when positive feedback is used.

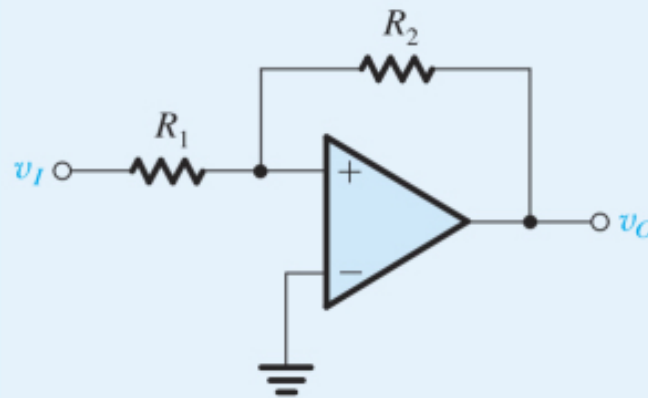

But A is not equal to $1 + R_2/R_1$. “instability is practically inevitable when positive feedback is used”

Statement is blatantly false!

DC model of actual op amp

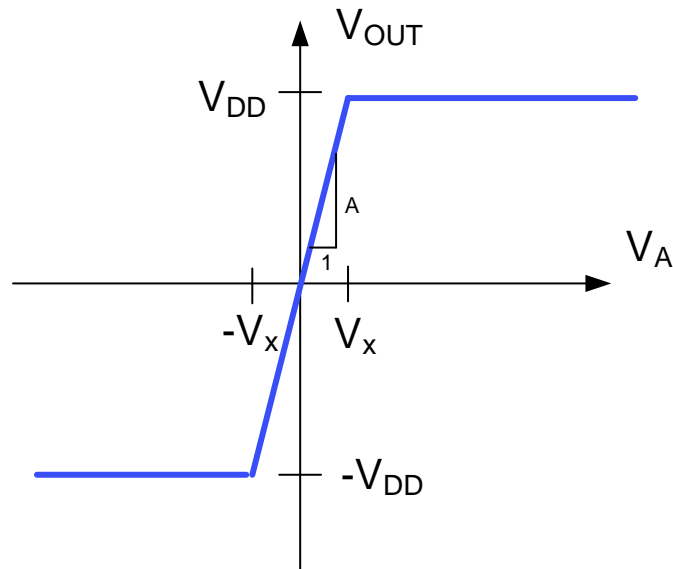
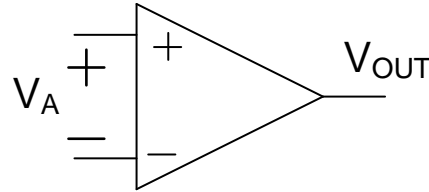

$$V_{OUT} = \begin{cases} V_{DD} & V_A > V_X \\ AV_A & -V_X < V_A < V_X \\ -V_{DD} & V_A < -V_X \end{cases}$$

Consider the negative feedback configuration

For convenience, assume $R_1=R_2=R$

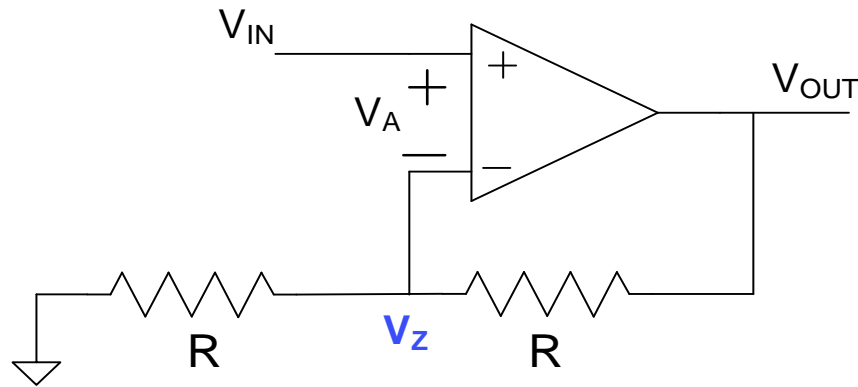

$$\left. \begin{aligned} V_Z &= \frac{V_{OUT}}{2} \\ V_{IN} &= V_A + V_Z \end{aligned} \right\}$$



$$V_A = V_{IN} - \frac{V_{OUT}}{2}$$

$$V_{OUT} = \begin{cases} V_{DD} & V_A > V_X \\ AV_A & -V_X < V_A < V_X \\ -V_{DD} & V_A < -V_X \end{cases} \quad \Rightarrow \quad V_{OUT} = \begin{cases} V_{DD} & V_{IN} - \frac{V_{DD}}{2} > V_X \\ \frac{2A}{2+A} V_{IN} \cong 2V_{IN} & -V_X - \frac{V_{DD}}{2} < V_{IN} < V_X + \frac{V_{DD}}{2} \\ -V_{DD} & V_{IN} + \frac{V_{DD}}{2} < -V_X \end{cases}$$

Consider the negative feedback configuration

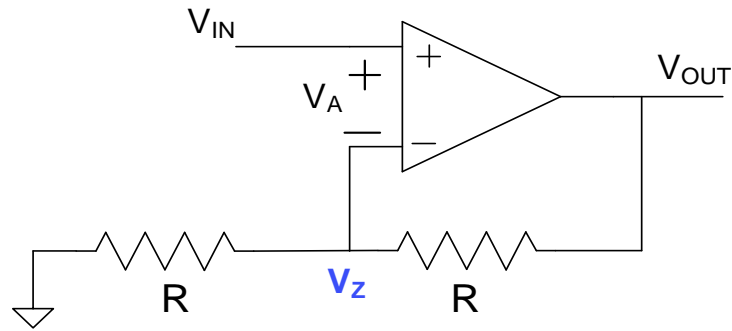

$$V_{OUT} = \begin{cases} V_{DD} & V_{IN} - \frac{V_{DD}}{2} > V_X \\ \frac{2A}{2+A} V_{IN} \cong 2V_{IN} & -V_X - \frac{V_{DD}}{2} < V_{IN} < V_X + \frac{V_{DD}}{2} \\ -V_{DD} & V_{IN} + \frac{V_{DD}}{2} < -V_X \end{cases}$$

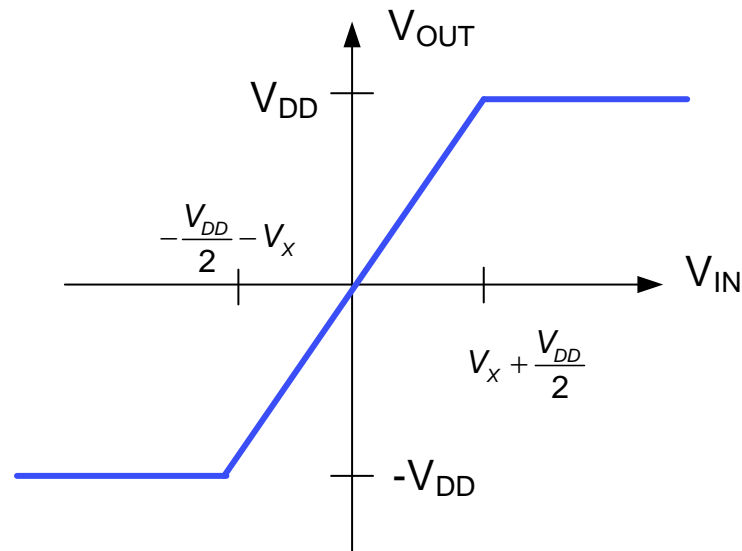

Consider the positive feedback configuration

For convenience, assume $R_1=R_2=R$

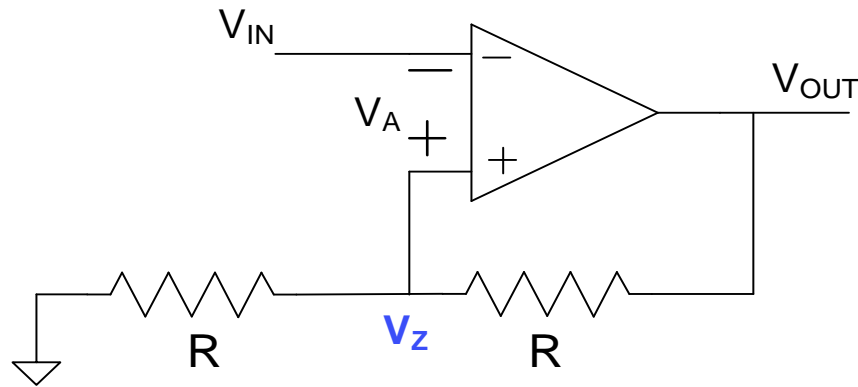

$$\left. \begin{aligned} V_Z &= \frac{V_{OUT}}{2} \\ V_{IN} &= -V_A + V_Z \end{aligned} \right\}$$



$$V_A = -V_{IN} + \frac{V_{OUT}}{2}$$

$$V_{OUT} = \begin{cases} V_{DD} & V_A > V_X \\ AV_A & -V_X < V_A < V_X \\ -V_{DD} & V_A < -V_X \end{cases}$$



$$V_{OUT} = \begin{cases} V_{DD} & -V_{IN} + \frac{V_{DD}}{2} > V_X \\ \frac{2A}{2+A} V_{IN} \cong 2V_{IN} & -V_{IN} + \frac{V_{DD}}{2} < V_X \text{ and } -V_{IN} + \frac{V_{DD}}{2} > -V_X \\ -V_{DD} & -V_{IN} - \frac{V_{DD}}{2} < -V_X \end{cases}$$

Consider the positive feedback configuration

For convenience, assume $R_1=R_2=R$

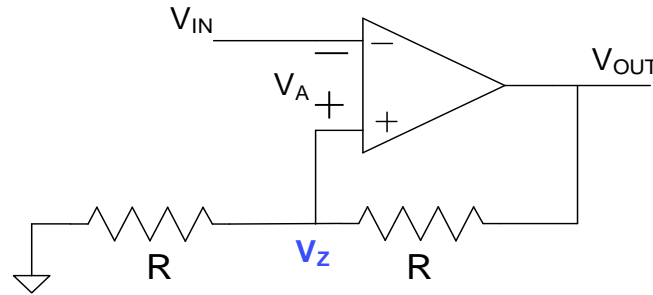

$$V_{OUT} = \begin{cases} V_{DD} & \frac{V_{DD}}{2} - V_X > V_{IN} \\ \frac{2A}{2+A} V_{IN} \cong 2V_{IN} & \frac{V_{DD}}{2} - V_X < V_{IN} < -\frac{V_{DD}}{2} + V_X \\ -V_{DD} & V_X - \frac{V_{DD}}{2} < V_{IN} \end{cases}$$

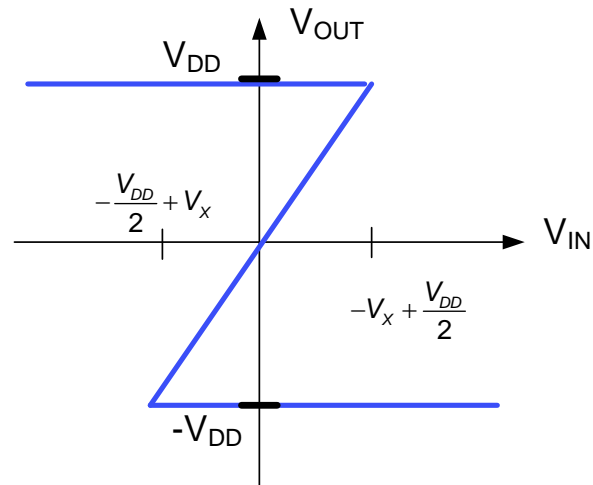

Note: Tripple-valued output in interval
So what will the output be?

Consider the negative feedback configuration

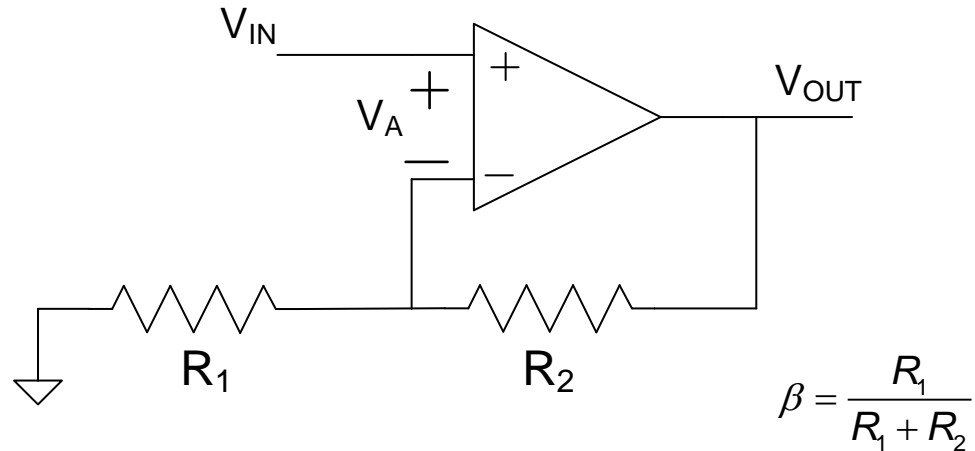

Assume single-pole amplifier model AND linear operation of the op amp

$$A(s) = \frac{pA_o}{s + p}$$

$$V_{OUT} = A(s)(V_{IN} - \beta V_{OUT})$$



$$A_{CL}(s) = \frac{V_{OUT}}{V_{IN}} = \frac{pA_o}{s + p(1 + \beta A_o)}$$

Single pole p_1

$$p_1 = -p(1 + \beta A_o)$$

Note pole in LHP on negative real axis !

Consider the positive feedback configuration

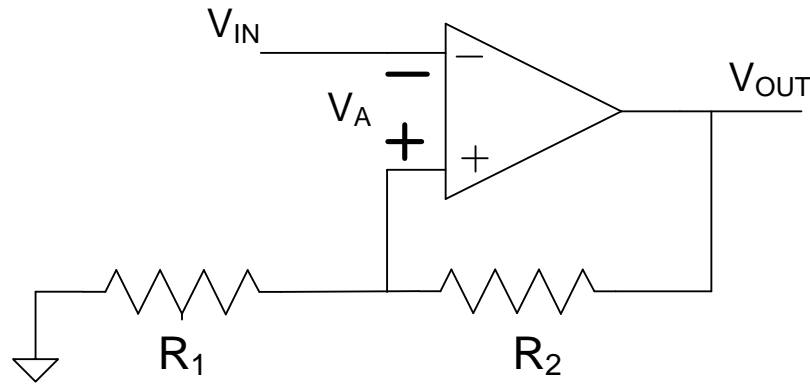

$$\beta = \frac{R_1}{R_1 + R_2}$$

Assume single-pole amplifier model

$$A(s) = \frac{pA_o}{s + p} \quad \longrightarrow \quad A_{CL}(s) = \frac{V_{OUT}}{V_{IN}} = \frac{-pA_o}{s + p(1 - \beta A_o)} \cong \frac{-pA_o}{s - p\beta A_o}$$

$$V_{OUT} = A(s)(\beta V_{OUT} - V_{IN})$$

$$p_1 = p(1 - \beta A_o) \simeq -p\beta A_o$$

Note pole in RHP on positive real axis !

The circuit is unstable when operating linearly and output will be of form Ke^{-pt}

Does this mean this amplifier is not useful?

Consider: Filter Structure with Feedback Amplifier

Bridged-T Feedback
(Termed SAB, STAR, Friend/Delyannis Biquad)

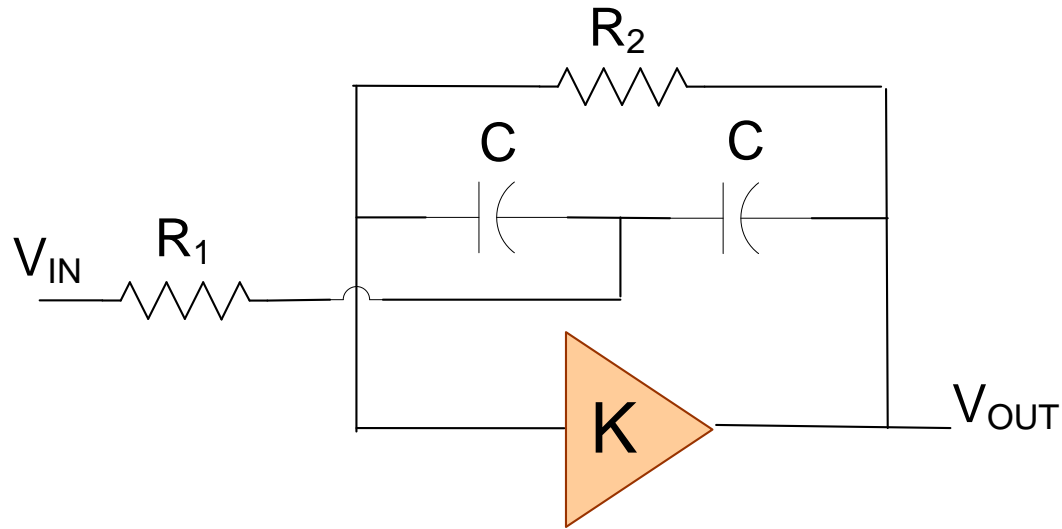

K is a small positive gain
want high input impedance on “ K ” amplifier

- Very popular filter structure
- One of the best 2nd-order BP filters
- Widely used by Bell System in 70's

Example: Filter Structure with Feedback Amplifier

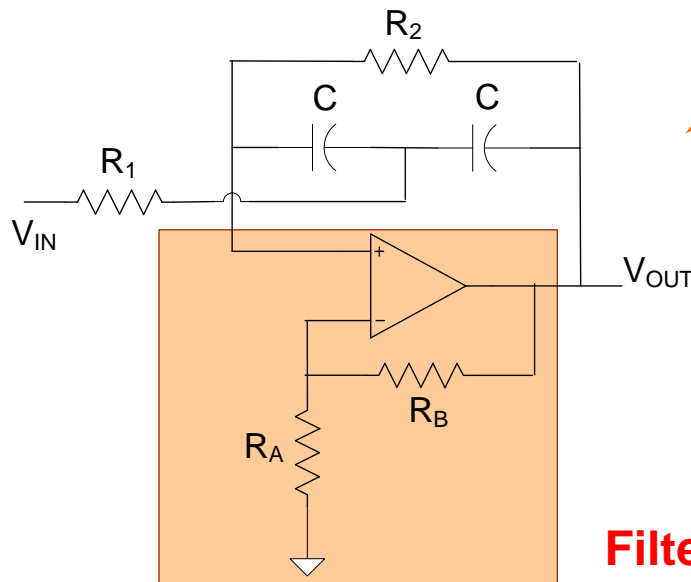
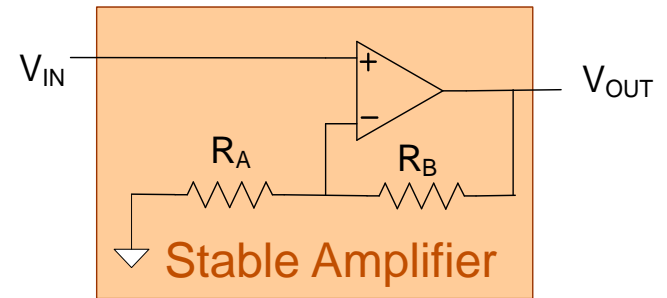
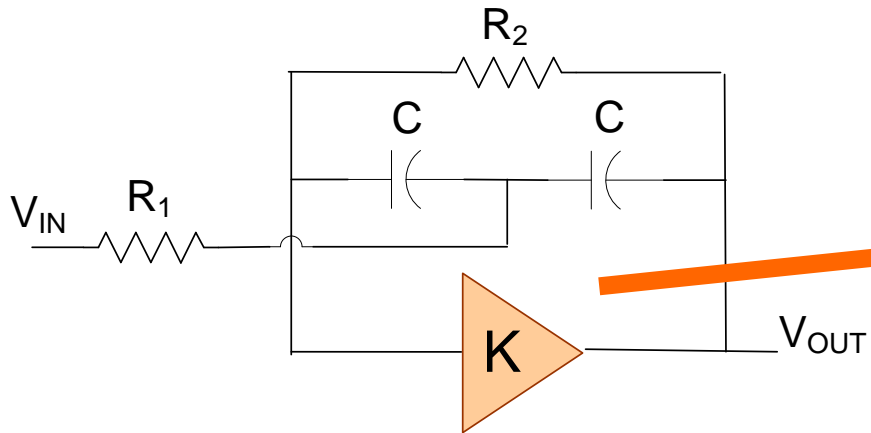

Filter is unstable !

Example: Filter Structure with Feedback Amplifier

Bridged-T Biquad
(with feed-forward)

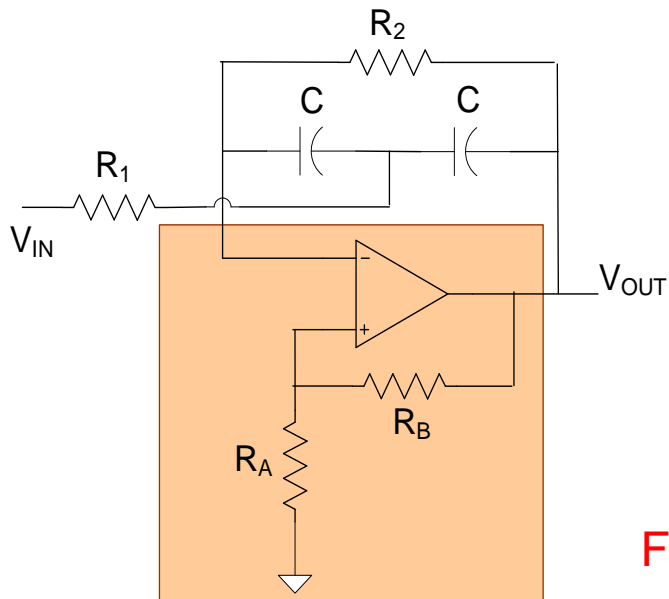
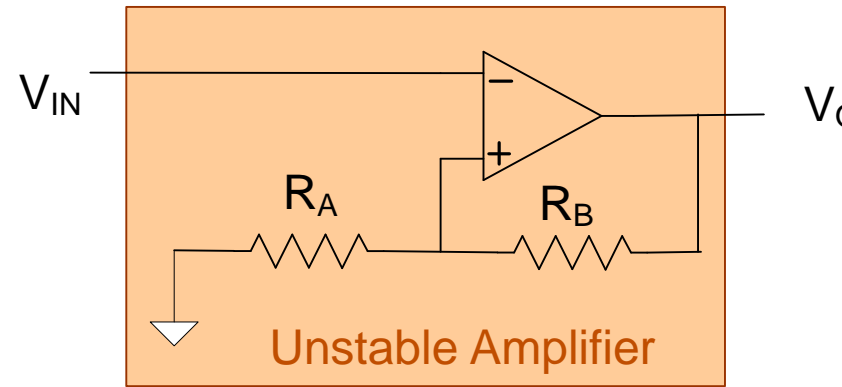
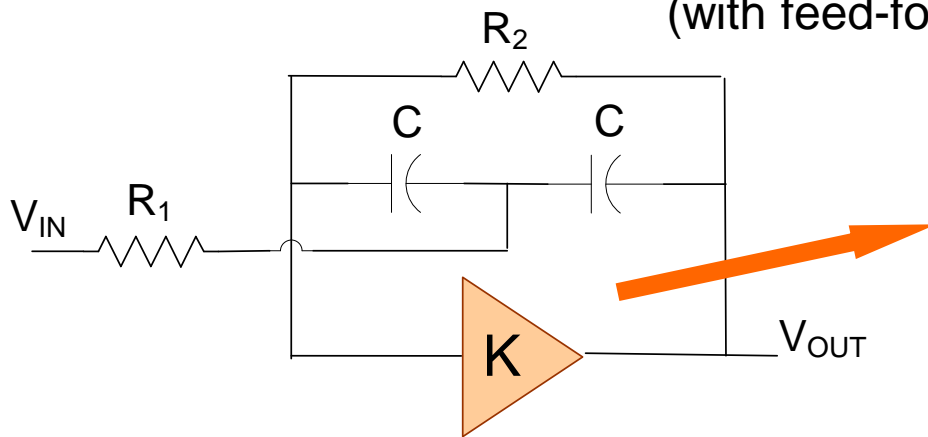

Friend/Deliyannis Biquad

Filter is stable !

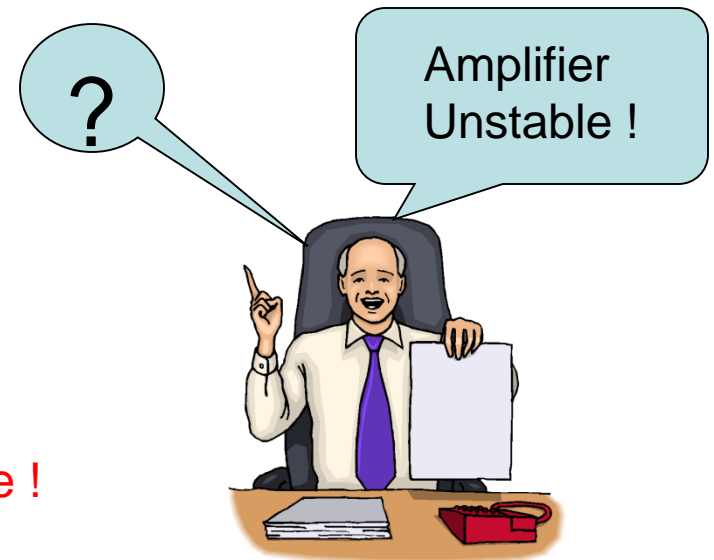

Very Popular Bandpass Filter

Friend-Deliyannis Biquad

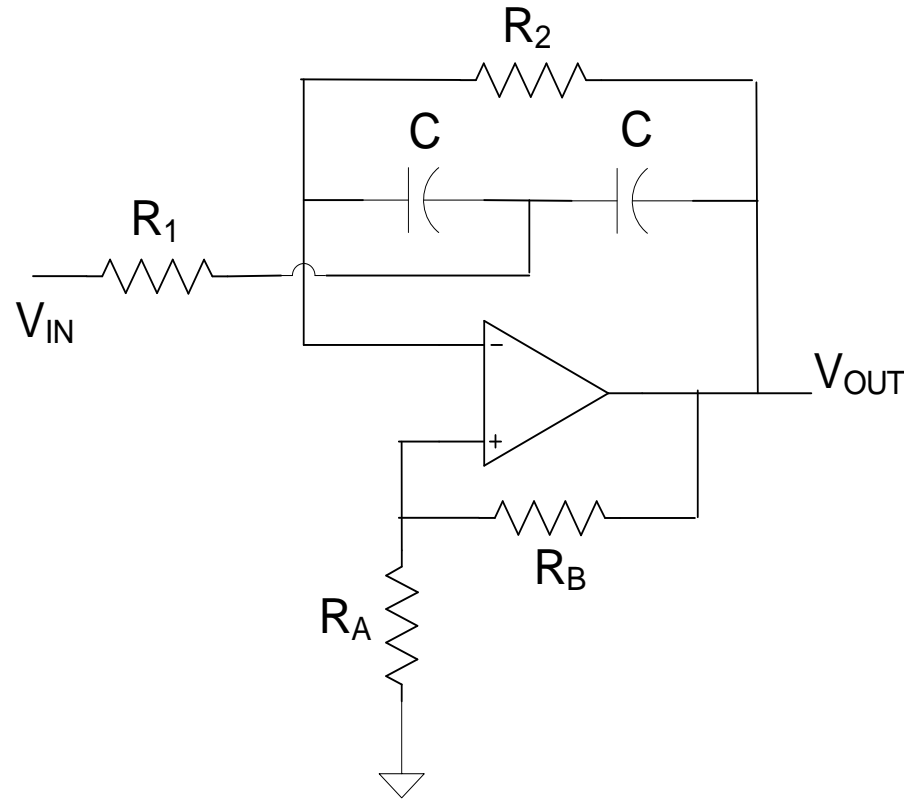

One of the best bandpass filters !!

Embedded finite gain amplifier is unstable!!

Stability of embedded amplifier is not necessary (or even desired)

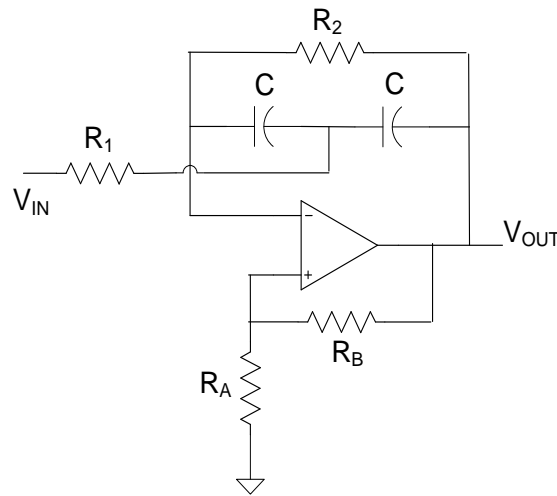

- Filter structure unstable with stable finite gain amplifier
- Filter structure stable with unstable finite gain amplifier
- **Stability of feedback network not determined by stability of amplifier!**

Why is this issue important?

How can you trust or be confident in your analysis and understanding if the principles you use to analyze even some of most basic circuits fail in slightly different circuits?

Transconductance vs Voltage Gain

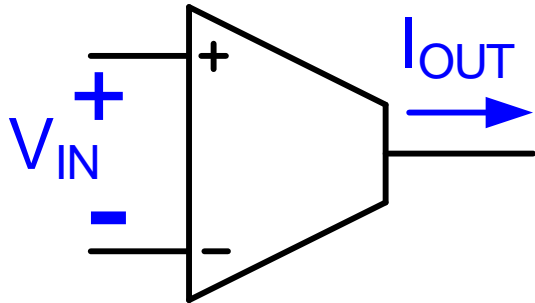

$$I_{OUT} = g_m V_{IN}$$

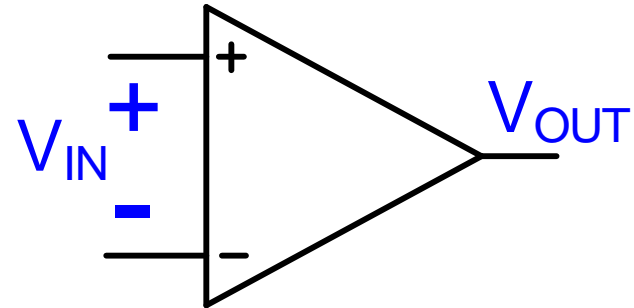

$$V_{OUT} = A_V V_{IN}$$

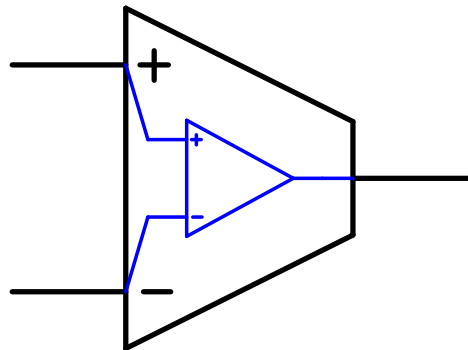

Same Circuit – Two Perspectives

OTA Circuits

OTA often used open loop

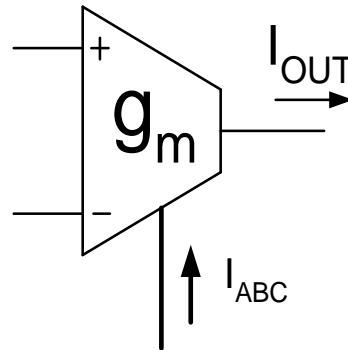

Recall: Op Amp almost never used open loop

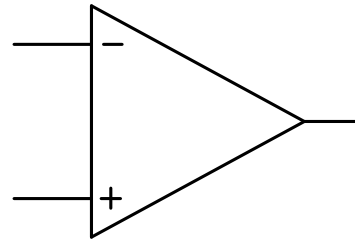

Since we just showed that the OTA is also a good high-gain op amp it seems there are conflicting statements

Challenge to students: Resolve what may appear to be conflicting statements. Will discuss this issue during the next lecture.

Standard Feedback Configuration

Voltage-Series Feedback (one of 4 types)

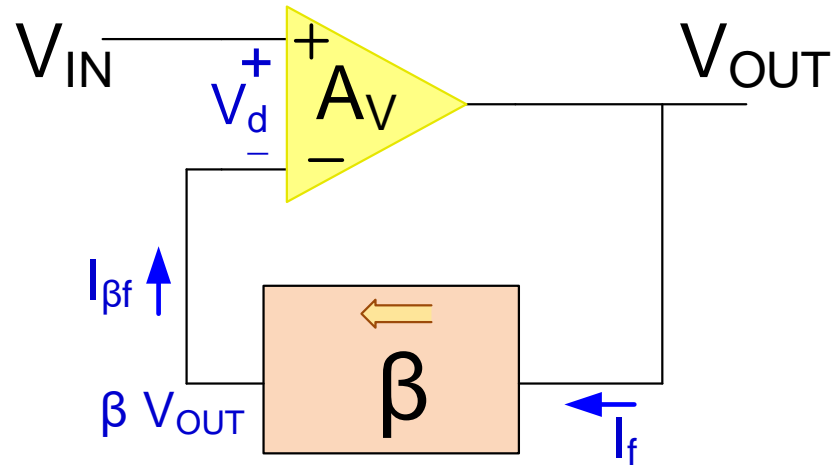

Assume ideal input and output impedance on A_V and β

$$\left. \begin{aligned} V_{\text{OUT}} &= A_V (V_{\text{IN}} - \beta V_{\text{OUT}}) \\ V_{\text{OUT}} &= A_V V_d \end{aligned} \right\} \Rightarrow \begin{aligned} A_{\text{VF}} &= \frac{A_V}{1 + \beta A_V} \underset{A_V \rightarrow \infty}{\approx} \frac{1}{\beta} \\ V_d &\underset{A_V \rightarrow \infty}{\approx} 0 \end{aligned}$$

Standard Feedback Configuration

Voltage-Series Feedback (one of 4 types)

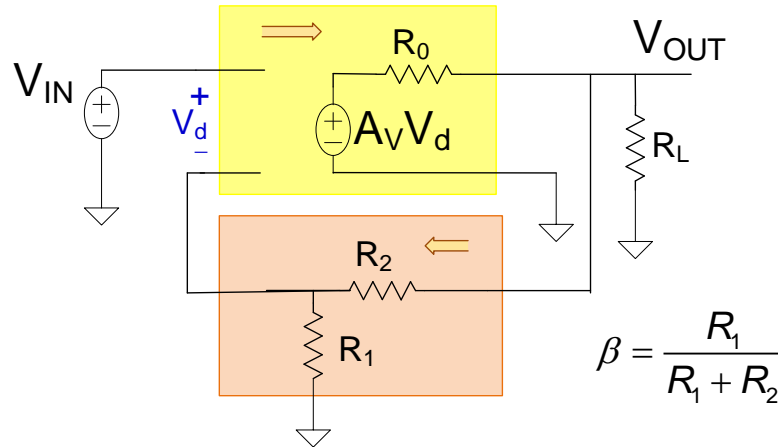

Define:

$$\theta = \frac{[R_1 + R_2] // R_L}{R_0 + [R_1 + R_2] // R_L}$$

Include Loading of nonideal A amplifier with β network

$$\left. \begin{aligned} A_{VEFF} &= \frac{V_{OUT}}{V_d} \\ V_d &= V_{IN} - \beta V_{OUT} \end{aligned} \right\} \Rightarrow \begin{aligned} V_{OUT} &= A_{VEFF} (V_{IN} - \beta V_{OUT}) \\ V_d &= V_{IN} \frac{1}{1 + \beta A_{VEFF}} \end{aligned}$$



$$A_{VF} = \frac{V_{OUT}}{V_{IN}} = \frac{A_{VEFF}}{1 + \beta A_{VEFF}} \underset{A_{VEFF} \rightarrow \infty}{\approx} \frac{1}{\beta}$$

$$V_d \underset{A_{VEFF} \rightarrow \infty}{\approx} 0$$

$$V_{OUT} = A_V V_d \left(\frac{[R_1 + R_2] // R_L}{R_0 + [R_1 + R_2] // R_L} \right) = \theta A_V V_d$$

$$A_{VEFF} = \theta A_V$$

$$A_{VF} = \frac{A_{VEFF}}{1 + \beta A_{VEFF}}$$

Example: Effects of Loading

Consider telescopic cascode op amp with $V_{EB1}=V_{EB3}=V_{EB5}=200\text{mV}$, $I_T=100\mu\text{A}$, $\lambda=.01\text{V}^{-1}$

Assume $R_1=1\text{K}$, $R_2=9\text{K}$, $R_L=10\text{K}$

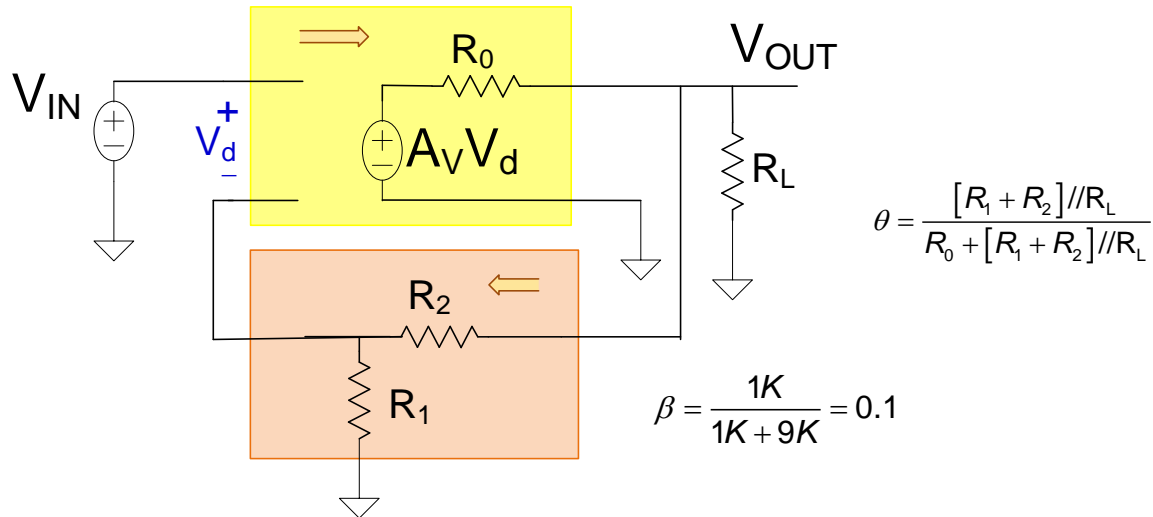
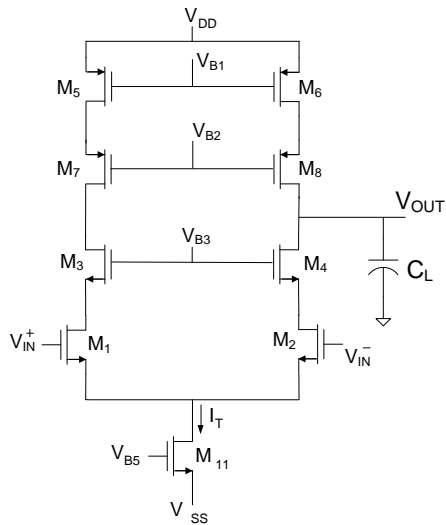

$$\theta = \frac{[R_1 + R_2] // R_L}{R_0 + [R_1 + R_2] // R_L}$$

$$\beta = \frac{1\text{K}}{1\text{K} + 9\text{K}} = 0.1$$

Without considering loading for dc input:

$$A_{V0} = \frac{2}{V_{EB1} (\lambda_1 \lambda_3 V_{EB3} + \lambda_5 \lambda_7 V_{EB5})}$$

$$g_{OUT} = g_{02} \frac{g_{04}}{g_{m4}} + g_{06} \frac{g_{08}}{g_{m8}}$$

$$A_{V0} = \frac{1}{V_{EB1}^2 \lambda^2} = 2.5 \times 10^6$$

$$g_{OUT} = 2\lambda I_{D2Q} \frac{\lambda I_{D4Q}}{2 \frac{I_{D4Q}}{V_{EB4}}} = \lambda^2 I_{D2Q} V_{EB4} = \lambda^2 \frac{I_T}{2} V_{EB4} = 10^{-9}$$

$$A_{VF} = \frac{A_{V0}}{1 + \beta A_{V0}} = \frac{2.5 \times 10^6}{1 + 2.5 \times 10^6 \times 0.1} = 9.999960$$

A_{VF} very close to the ideal value of $\frac{1}{\beta} = 10.000$

Example: Effects of Loading

Consider telescopic cascode op amp with $V_{EB1}=V_{EB3}=V_{EB5}=200\text{mV}$, $I_T=100\mu\text{A}$, $\lambda=.01\text{V}^{-1}$

Assume $R_1=1\text{K}$, $R_2=9\text{K}$, $R_L=10\text{K}$

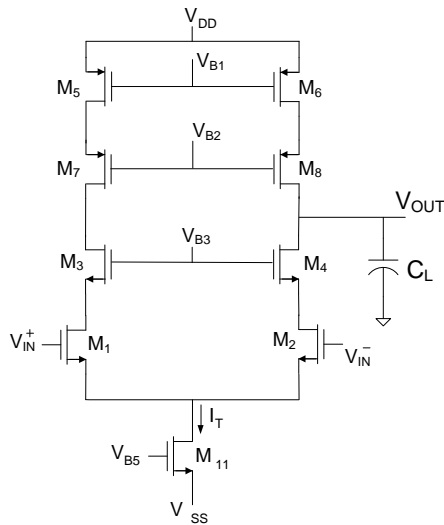

$$A_{V0} = \frac{2}{V_{EB1}(\lambda_1\lambda_3V_{EB3} + \lambda_5\lambda_7V_{EB5})}$$

$$g_{OUT} = g_{02} \frac{g_{04}}{g_{m4}} + g_{06} \frac{g_{08}}{g_{m8}}$$

$$A_{V0} = \frac{1}{V_{EB1}^2 \lambda^2} = 2.5 \times 10^6$$

$$g_{OUT} = 2\lambda I_{D2Q} \frac{\lambda I_{D4Q}}{2 \frac{I_{D4Q}}{V_{EB4}}} = \lambda^2 I_{D2Q} V_{EB4} = \lambda^2 \frac{I_T}{2} V_{EB4} = 10^{-9}$$

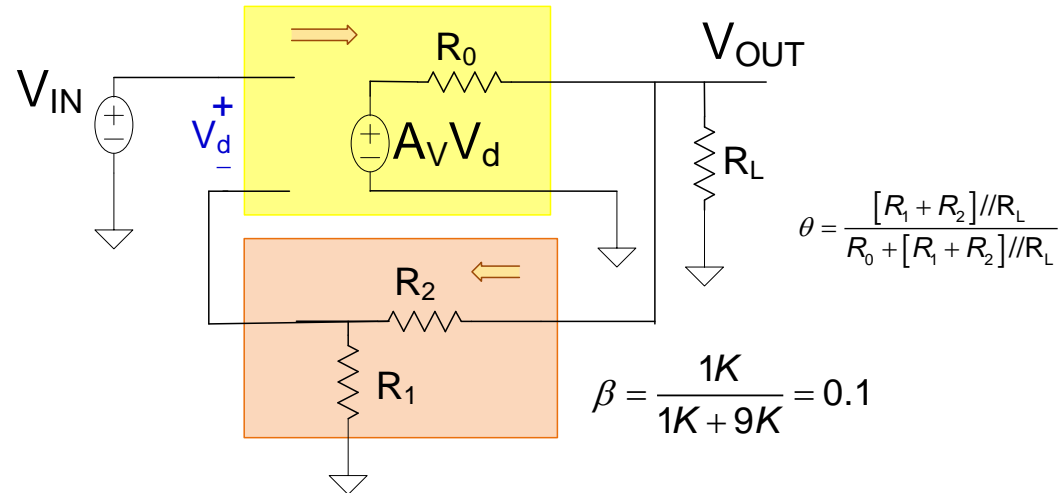

With Loading for dc input:

$$A_{VF} = \frac{A_{VEFF}}{1 + \beta A_{VEFF}} = \frac{12.5}{1 + 1.25} = 5.5$$

$$R_0 = 10^9 \Omega$$

$$\theta = \frac{[R_1 + R_2] // R_L}{R_0 + [R_1 + R_2] // R_L} = \frac{5\text{K}}{10^9 + 5\text{K}} \cong 5 \times 10^{-6}$$

$$A_{VEFF} = \theta A_V = 5 \times 10^{-6} \times 2.5 \times 10^6 = 12.5$$

$$A_{VF} = \frac{A_{VEFF}}{1 + \beta A_{VEFF}} = \frac{12.5}{1 + 1.25} = 5.5$$

Almost useless as a FB amplifier !

Effective Gain of Operational Amplifiers

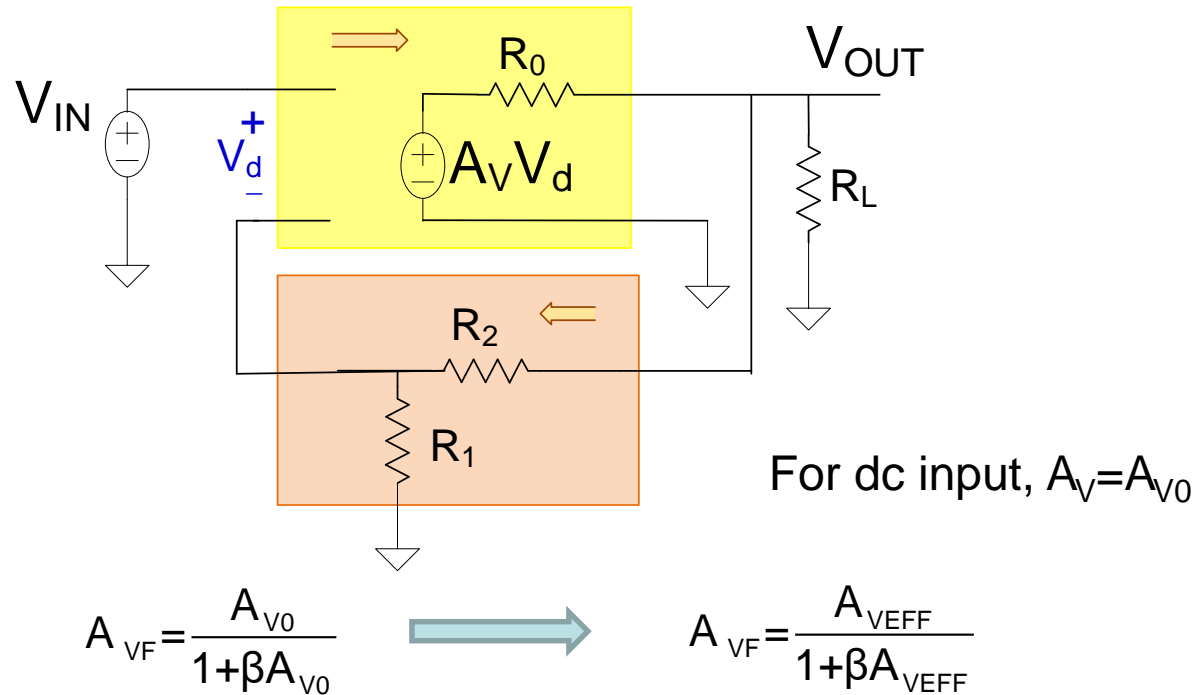

The open loop gain of an operational amplifier used in a FB configuration must include the loading of the feedback network and load resistor

Some FB networks cause little or no loading and others can be significant

Often a buffer stage is added to the output of the op amp when used in FB applications driving “heavy” loads

Are these “high gain” amplifiers really high gain amplifiers?

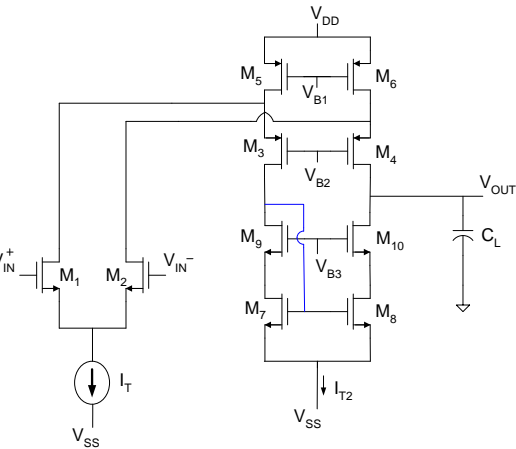
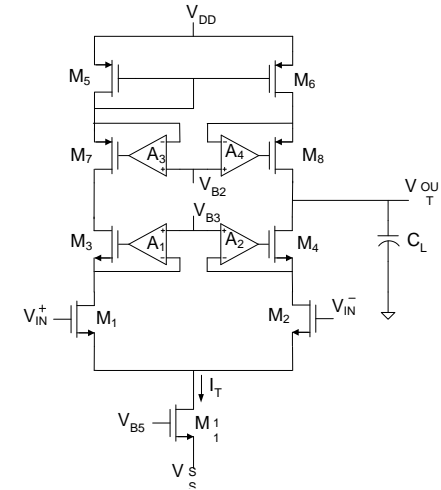
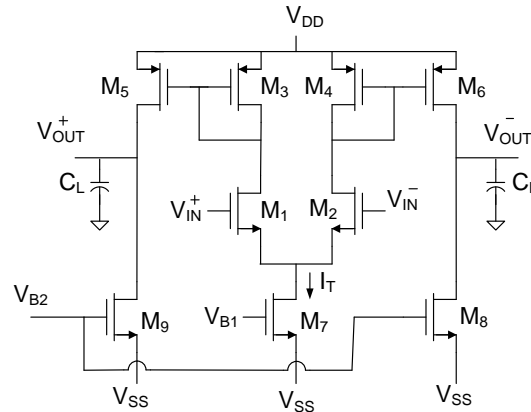
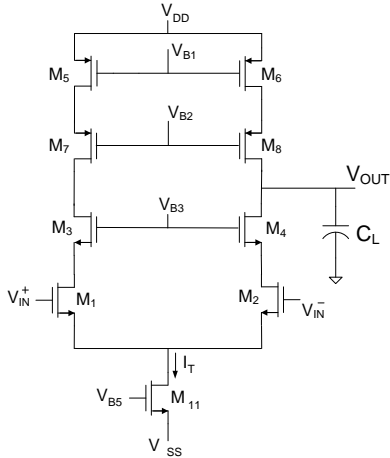

- All have high voltage gain if not driving heavy loads !
- Output buffer stage can be added to all to drive heavy loads and maintain high effective voltage gain
- All have very high output impedance so are inherently transconductance amplifiers
- None have large transconductance gain so are not good for feedback applications as transconductance amplifiers

Are these “high gain” amplifiers really high gain amplifiers?

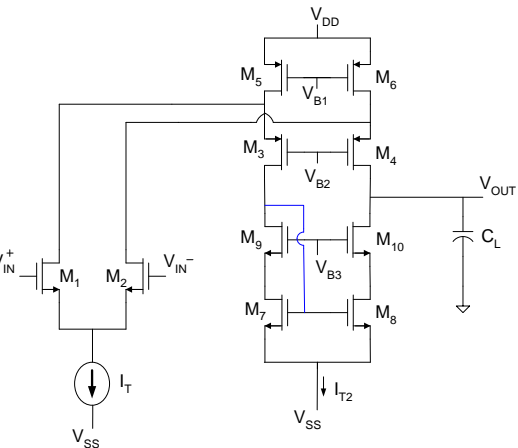
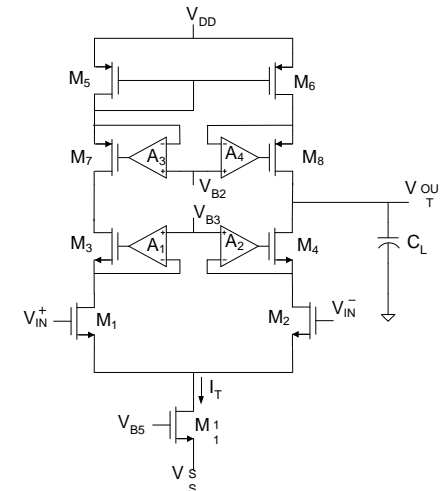
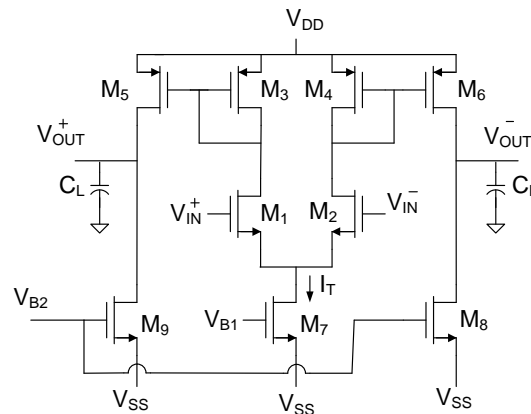
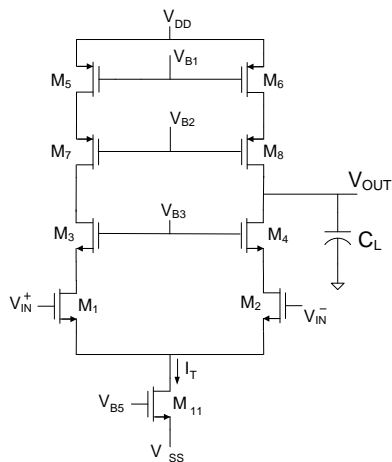

- High voltage gain op amps are seldom used open loop to build voltage amplifiers
- Since all have low transconductance gains, can be used open-loop in transconductance applications
- When used in transconductance applications, often termed Operational Transconductance Amplifiers (OTAs)
- When intended to be used as OTAs, voltage or current control input often added to electrically control the gain.

Are these “high gain” amplifiers really high gain amplifiers?

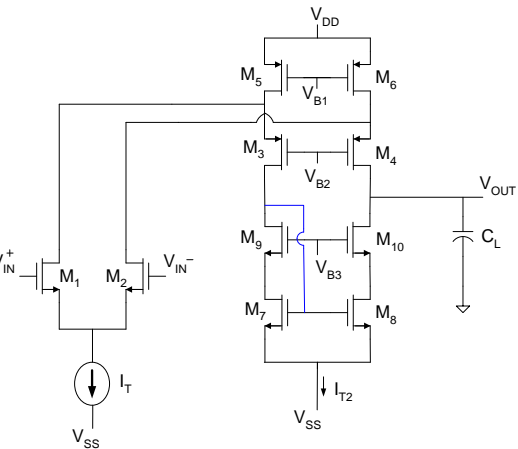
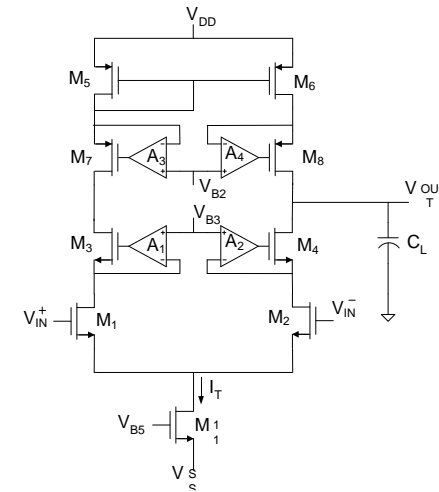
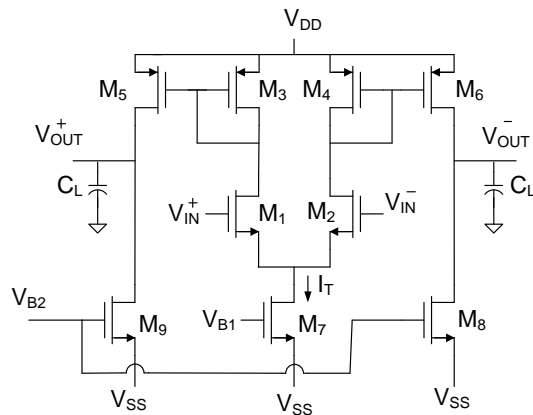
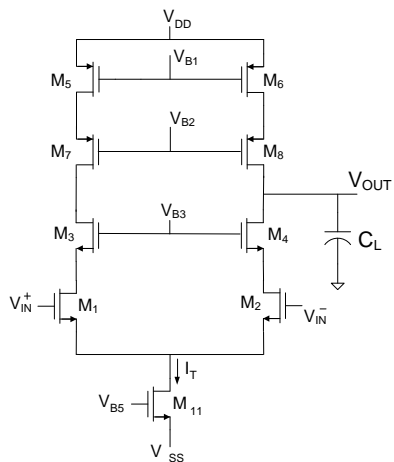

Are these high gain voltage amplifiers?

Are these high gain transconductance amplifiers?

Are these high gain current amplifiers?

Are these high gain transresistance amplifiers?

Are these “high gain” amplifiers really high gain amplifiers?

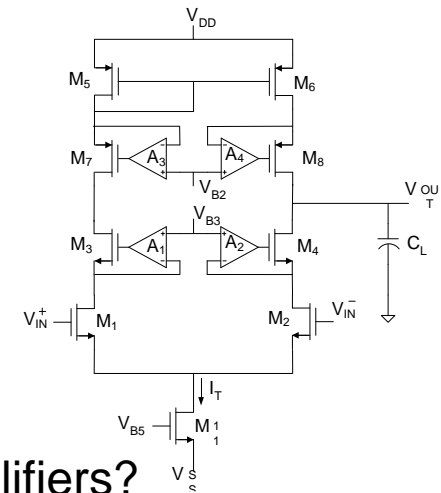
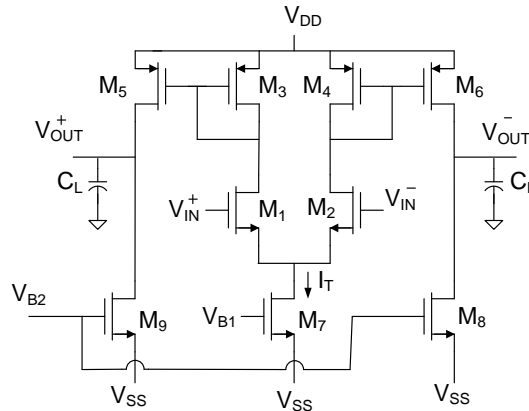
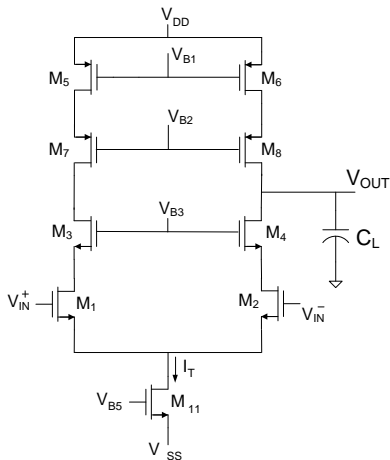

Are these high gain voltage amplifiers?

Yes if loading ignored

Are these high gain transconductance amplifiers?

No!

Are these high gain current amplifiers?

No input current but if modified with low impedance shunt at input, have low current gain

Are these high gain transresistance amplifiers?

No input current but if modified with low impedance shunt at input, transresistance gain would not be high even if loading of output neglected

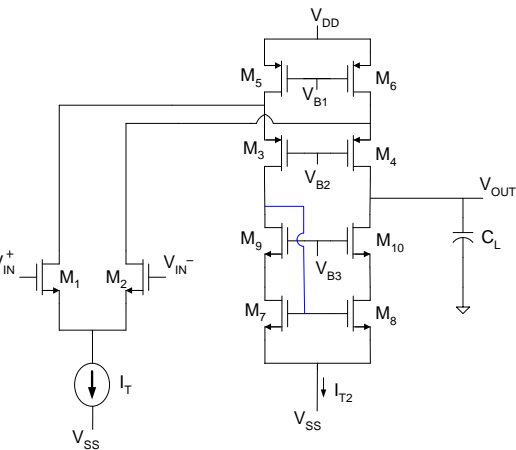



Stay Safe and Stay Healthy !

End of Lecture 10